

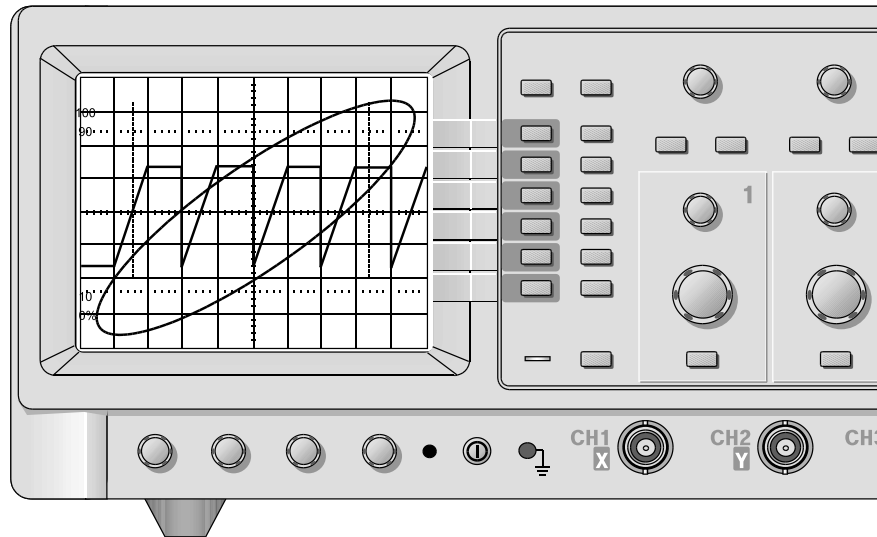

Oscilloscope

OS-5100RA/RB

Analog Readout Oscilloscope
Operation Manual





Oscilloscope

OS-5100RA/RB

Analog Readout Oscilloscope
Operation Manual

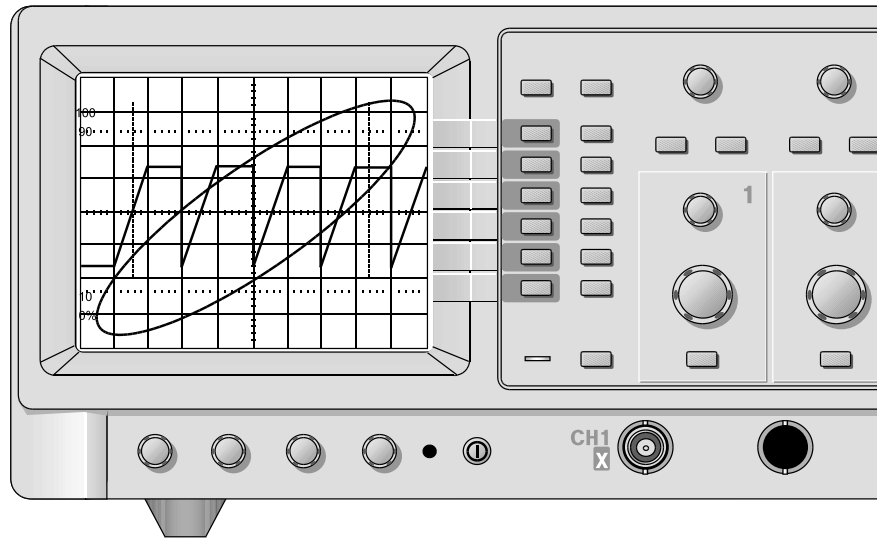

DECLARATION OF CONFORMITY

according to ISO/IEC Guide 22 and EN 45014

Manufacturer's Name: EZ Digital Co., Ltd.

Manufacturer's Address: 222-28, Nae-dong, Ojeong-gu, Bucheon-si,
Gyeonggi-do R. O. K, 421-160

Declares that the product:

Product Name: OSCILLOSCOPE

Model Numbers: OS-5100RA
OS-5100RB

Date: Feb. . 1997.

Conforms to the following product specifications:

Safety: EN 61010-1 : 1993 + A2:1995
(IEC 10101 : 1990 + A1:1992
+ A2:1995, modified)
Certified by TUV Rheinland

EMC: EN 55011 : 1991
EN 61000-3-2 :1995
EN 61000-3-3 :1995
EN 50082-1 :1992
Certified by VDE

Supplementary Information:

The product herewith complies with the requirements of the Low Voltage Directive 73/23/EEC and the EMC Directive 89/336/EEC.

Bucheon, Gyeonggi

Location

C. Y. Kim

Cheol Young Kim

Quality Assurance Manager

WARRANTY

Warranty service covers a period of one year from the date of original purchase.

In case of technical failure within a year, repair service will be provided by our service center or sales outlet free of charge.

We charge customers for repairs after the one year warranty period has been expired.

Provided that against any failure resulted from the user's negligence, natural disaster or accident, we charge you for repairs regardless of the warranty period.

For more professional repair service, be sure to contact our service center or sales outlet.

Introduction

Thank you for purchasing a EZ product. Electronic measuring instruments produced by EZ Digital are high technology products made under strict quality control. We guarantee their exceptional precision and utmost reliability. For proper use of the product, please read this operation manual carefully.

NOTE

1. To fully maintain the precision and reliability of the product use it within the range of standard setting (temperature 10 35 , humidity 45% 85%).
2. After turning of power, please allow a pre-heating period of as long as some 15 minutes before use.
3. This equipment should be used with a triple line power cord for safety.
4. For quality improvement the exterior design and specifications of the product can be changed without prior notice.
5. If you have further questions concerning use, please contact the EZ Digital service center or sales outlet.

Safety Summary

Safety Precautions

Please take a moment to review these safety precautions. They are provided for your protection and to prevent damage to the oscilloscope. This safety information applies to all operator and service personnel.

Caution and warning statements.

CAUTION : Is used to indicate correct operating or maintenance procedures in order to prevent damage to destruction of the equipment or other property.

WARNING : Calls attention to a potential danger that requires correct procedures or practices in order to prevent personal injury.



Caution (refer to accompanying documents) and Warning.



Protective ground (earth) symbol.

CONTENTS

1. PRODUCT DESCRIPTIONS	2
1-1. INTRODUCTION	2
1-2. SPECIFICATION	2
1-3. PRECAUTIONS	6
1-3-1. Line Voltage Selection	6
1-3-2. Installation and handling precautions	6
1-4. ACCESSORY	7
1-5. SYMBOL	7
1-6. SAFETY	7
1-7. EMC	7
2. OPERATING INSTRUCTIONS	8
2-1. FRONT PANEL FUNCTION	8
2-2. REAR PANEL FUNCTION	11
2-3. INSTALLATION AND BASIC OPERATION	12
2-3-1. Character Display	12
2-3-2. Initial Display	13
2-3-3. Probe Adjustment	14
2-3-4. Vertical Mode (Vert Mode)	15
2-3-5. Channel Connections	17
2-3-6. Horizontal Display (Hori Display)	18
2-3-7. Trigger Mode	19
2-3-8. Trigger Source	20
2-3-9. Trigger Coupling	21
2-3-10. Auto Setup	22
2-3-11. Cursor	23
2-3-12. X-Y Cursor	24
2-4. MEASUREMENT APPLICATIONS	25
2-4-1. Voltage Measurements	25
2-4-2. Time Interval Measurements	27
2-4-3. Frequency Measurements	29
2-4-4. Phase Difference Measurements	30
2-4-5. Transition Time Measurements	32

3. USER MAINTENANCE GUIDE	34
3-1. CLEANING	34
3-2. CALIBRATION INTERVAL	34
4. DIAGRAMS	35
4-1. EXTERNAL VIEWS	35
4-2. BLOCK DIAGRAM	36

1. PRODUCT DESCRIPTIONS

1-1. INTRODUCTION

OS-5100SRS is the 100MHz, 4(2) channels, 8(4) traces CRT READOUT which has excellent functions including wide band width, high sensitivity, two timebase generator, delay sweep and divided TV trigger signal. It reduces the measurement error, and uses 6-inch squared type CRT with internal fluorescent scale which enables to take the photograph of observed waveform.

1-2. SPECIFICATIONS

SPEC \ MODEL	OS-5100SRS
* CRT	
1) Configuration	6-inch rectangular screen with internal graticule : 8 X 10 DIV (1DIV = 1cm), marking for measurement of rise time. 2mm subdivisions along the central axis.
2) Accelerating potential	+11.5kV approx. (ref. Cathode)
3) Phosphor	P31 (standard)
4) Focussing	Provided
5) Trace rotation	Provided
6) Scale illumination	Provided
7) Intensity control	Provided
8) Character illumination	Provided
* Z-Aix input (Intensity Modulation)	
1) Input signal	Positive going signal decreases intensity $\pm 5V_{p-p}$ or more signal cases noticeable modulation at normal intensity setting
2) Band-width	DC ~ 2MHz (-3dB)
3) Coupling	DC
4) Input impedance	About 20 ~ 30 k Ω
5) Maximum input voltage	30V (DC + peak AC)

SPEC	MODEL	OS-5100SRS
* Vertical Deflection		
1) Band-width (-3dB)	DC coupled	(X1) DC to 100MHz normal 2mV/DIV : DC to 50MHz
	AC coupled	(X1) 10Hz to 100MHz normal 2mV/DIV : Dc to 50MHz
2) Modes		5100RA : CH1, CH2, CH3, DUAL, ADD, QUAD, ALT, CHOP, CH2 INV 5100RB : CH1M CH2M DUAL, ADD, ALT, CHOP, CH2 INV
4) Deflection Factor		2mV/DIV to 5V/DIV in 11 calibrated steps of a 1-2-5 sequence Continuously variable between steps at least 2:5 (OS-5100RA has channel 3 and channel 4 which have 0.1V/DIV and 0.5V/DIV)
4) Accuracy		Normal : $\pm 3\%$
5) Input impedance		Approx. 1 M Ω in paralled with 25pF
6) Maximum input voltage		Direct : 400V (DC + peak AC)
7) Input coupling		AC/DC/GND
8) Rise time		3.5ns or less (2mV/DIV : less than 7ns)
9) CH1 out		50mV/DIV into 50 Ω : DC to 20MHz (-3dB)
10) Polarity inversion		CH2 only
11) Signal delay		Delay cable supplied
* Horizontal deflection		
1) Display		A, ALT, B. X-Y, B TRIG'D
2) Time base A		50ns/DIV to 0.5s/DIV in 22 calibrated steps of a 1-2-5 sequence, uncalibrated continuous control between steps at least 2:5
3) Hold-off time		Variable with the holdoff control
4) Time base B		50ns/DIV to 0.5s/DIV in 22 calibrated steps at a 1-2-5 sequence
5) Delayed sweep		1 DIV or less to 10 DIV or more
6) Sweep magnification		10 times (maximum sweep rate : 5ns/DIV)
7) Accuracy		$\pm 3\%$, $\pm 5\%$ (X 10)

SPEC \ MODEL	OS-5100SRS												
* Trigger system													
1) Modes	AUTO, NORM, TV-V, TV-H, SINGLE												
2) Source	5100RA : CH1, CH2, LINE, CH3, CH4, VERT 5100RB : CH1, CH2, VERT, EXT, LINE												
3) Coupling	AC, DC, HF-R, LF-R												
4) Slope	+ or -												
5) Sensitivity and Frequency AUTO, NORM	<table border="1"> <thead> <tr> <th>Freq.</th> <th>Internal</th> <th>External</th> <th>VERT</th> </tr> </thead> <tbody> <tr> <td>DC~10MHz</td> <td>0.5DIV</td> <td>0.15Vp-p</td> <td>1.5DIV</td> </tr> <tr> <td>10MHz~100MHZ</td> <td>1.5DIV</td> <td>0.6Vp-p</td> <td>3.0DIV</td> </tr> </tbody> </table>	Freq.	Internal	External	VERT	DC~10MHz	0.5DIV	0.15Vp-p	1.5DIV	10MHz~100MHZ	1.5DIV	0.6Vp-p	3.0DIV
Freq.	Internal	External	VERT										
DC~10MHz	0.5DIV	0.15Vp-p	1.5DIV										
10MHz~100MHZ	1.5DIV	0.6Vp-p	3.0DIV										
TV-V, TV-H	1Div or more 0.1 Volt (trigger part)												
6) External trigger (OS-5100RA CH3 or CH4) Input impedance	Approx. 1 M Ω in paralalled with 25pF												
7) Maximum input voltage	400V (DC + peak AC)												
* X-Y operation													
1) X accuracy	$\pm 6\%$, Frequency response : DC~2MHz(-3dB) (Same on channel 1 except this)												
2) Y accuracy	Same on CH2												
3) X-Y phase difference	Within 3° (up to 100kHz at DC)												
* Power Supply													
1) Voltage range	90~250VAC (fuse:1.6A/250V, Time Lag)												
2) Frequency	48 ~ 440Hz												
3) Power consumption	Max. 50W												
* Physical Charac.													
1) Weight	8 kg												
2) Dimension	328mm(W) X 150mm(H) X 392mm(D)												

SPEC \ MODEL	OS-5100SRS
* Environmental Charac.	
1) Temperature range for rated operation	+10 to +35 (+50 to +95)
2) Max. ambient operating temperature	0 to +40 (+32 to +104) -20 to +70 (-4 to +158)
3) Max. storage temperature	
4) Humidity range for rated operation	45% to 85% RH
5) Max. ambient operating humidity	35% to 85% RH
* READOUT	
1) Cursor Readout	V, T, 1/ T
2) Frequency Counter	Marking for Auto setup from 100Hz to 50MHz
3) Resoultion	1/100 DIV
* Probe Adjust	
1) probe Adjustment	About 1KHz 0.5Vp-p(±2%) square wave. Duty rate : 50%

1-3. PRECAUTION

Before you operate this instrument, follow the following procedure to ensure safe operation and to prevent any damage to the instrument.

1-3-1. Line Voltage Selection

1. Voltage Range : 90 ~ 250VAC
2. Frequency Range : 48 ~ 440 Hz
3. Fuse : 250V / 1.6A(Time Lag)

Caution This product has the ground chassis(3 wire power cord is used).
Check whether any other equipment connecting with this product requires the transformer before use.
Do not directly connect it to the AC power nor to the circuit directly connected to the AC power.
Otherwise serious personal injury or damage to this product for a long time without trouble.

1-3-2. Installation and Handling Precautions

when placing the OS-5100RA(RB) in service at your workplace, observe the following precautions for best instrument performance and longest service life.

1. Avoid placing this instrument in an extremely hot or cold place. Specifically, don't leave this instrument in a close car, exposed to sunlight in midsummer, or next to a space heater.
2. Do not use this instrument immediately after bringing it in from the cold. Allow time for it to warm to room temperature. Similarly, don't move it from a warm place to a very cold place, as condensation might impair its operation.
3. Do not expose the instrument to wet or dusty environments.
4. Do not place liquid-filled containers (such as coffee cups) on top of this instrument. A spill could serious damage the instrument.
5. Do not use this instrument where it is subject to severe vibration, or strong blows.

6. Do not place heavy objects on the case, or block the ventilation holes.
7. Do not use this oscilloscope in strong magnetic fields, such as near motors.
8. Do not insert wires, tools, etc. through the ventilation holes.
9. Do not leave a hot soldering iron near the instrument.
10. Pre-heating is necessary after moving.
11. Do not place this oscilloscope face down on the ground, or damage to the knobs may result.
12. Do not use this instrument upright while BNC cables are attached to the rear-panel connectors. This will damage the cable.
13. Do not apply voltages in excess of the maximum ratings to the input connectors or probes.
14. This oscilloscope is to use UL listed double insulated probes only.

1-4. ACCESSORY

The following accessories are included in the packing of this product :

1. Operating manual : 1 copy
2. AC power cord : 1 EA
3. Probe : 2 EA (option)
4. Fuse : 2 EA

1-5. SYMBOL



Caution : refer to accompanying documents.



Danger : High Voltage.



Protective ground (earth) terminal.

1-6. SAFETY

This instrument has been designed and tested in accordance with IEC Publication 1010-1 (overvoltage category , pollution degree 2), Safety requirements for electrical equipment for measurement, control, and laboratory use. The CENELEC regulations EN 61010-1 correspond to this standard. This instruction manual contains important information and warning which have to be followed by the user to ensure safe operation and to retain the oscilloscope in a safe condition.

The case, chassis and all measuring terminals are connected to the protective earth contact of the appliance inlet. The instrument operates according to Safety Class I (three-conductor power cord with protective earthing conductor and a plug with earthing contact).

The mains/line plug shall only be inserted in a socket outlet provided with a protective earth contact. The protective action must not be negated by the use of an extension cord without a protective conductor.

The mains/line plug should be inserted before connections are made to measuring circuits.

The grounded accessible metal parts (case, sockets, jacks) and the mains/line supply contacts (line/live, neutral) of the instrument have been tested against insulation breakdown with 1500Vrms.

1-7. EMC

This instrument conforms to the European standards regarding the electromagnetic compatibility. The applied standards are : Generic immunity standard EN50082-1, (for residential, commercial and light industry environment) Emission standard EN55011 (for ISM Equipment), EN61000-3-2, EN61000-3-3.

2. OPERATING INSTRUCTIONS

2-1. FRONT PANEL FUNCTION

OS-5100RA

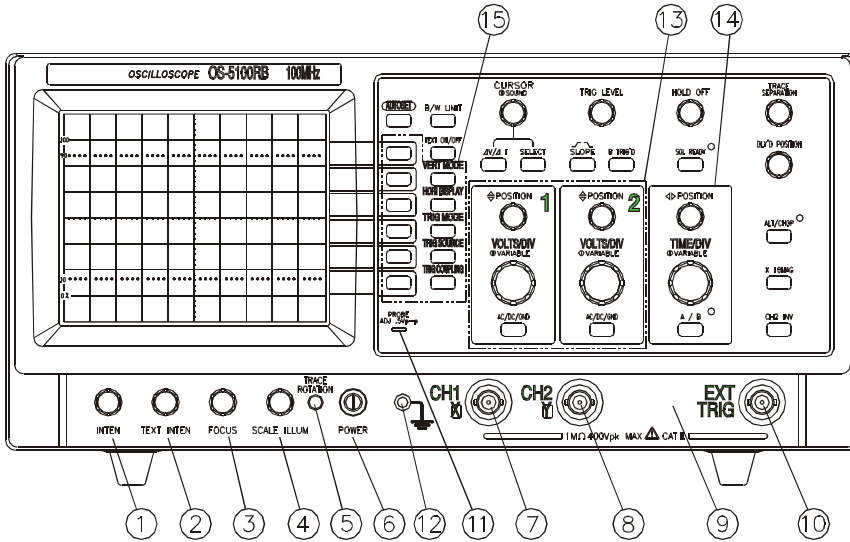

OS-5100RB

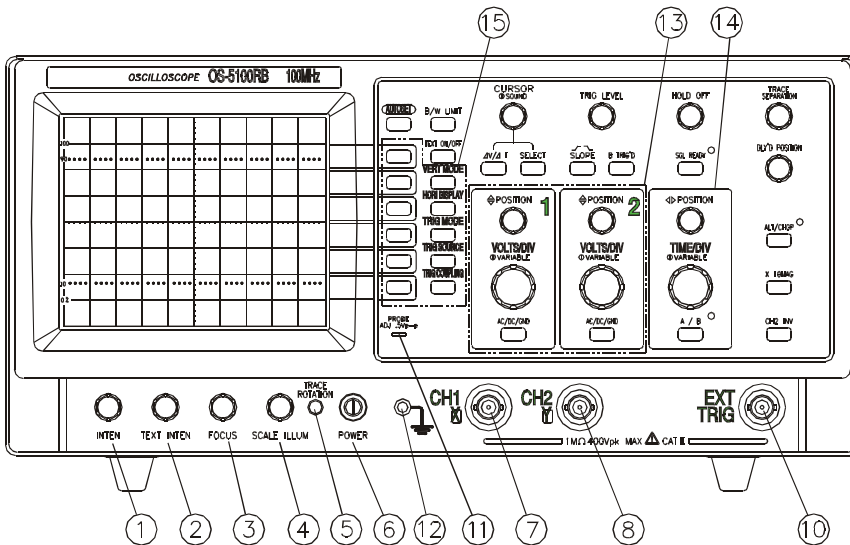

1. INTENSITY : Clockwise rotation increases sweep brightness.
2. TEXT INTENSITY : Clockwise rotation increases character brightness.
3. FOCUS : To obtain maximum trace sharpness.
4. SCALE ILLUMINATION : To adjust graticule illumination for photographing the CRT display.
5. TRACE ROTATION : Allows screwdriver adjustment of trace alignment with regard to the horizontal graticule lines of the CRT.
6. POWER SWITCH : Push in to turn instrument power on and off.
7. CH1 X IN CONNECTOR : For applying an input signal to vertical amplifier channel 1, or to the X-axis(horizontal) amplifier during X-Y operation.
8. CH2 Y IN CONNECTOR : For applying an input signal to vertical amplifier channel 2, or to the Y-axis(vertical) amplifier during X-Y operation.
9. CH 3 CONNECTOR : For applying an input signal to vertical amplifier Channel 3.(only for 5100RA)
10. CH 4 CONNECTOR : For applying an input signal to vertical amplifier channel 4. (only for 5100RA) For applying external trigger signal to the trigger circuits.
11. PROBE ADJUST : Outputs square wave (0.5V, 1kHz) to calibrate probe and vertical amplifier.
12. GROUND CONNECTOR : Provides an attachment point for a separate ground lead.
13. VERTICAL BLOCK
 - a. POSITION : The key which moves the Y axis position of the waveform from CH1~4.
 - b. VOLTS/DIV : Changes from 2mV to 5V with 1-2-5 step. When push key, operate as UNCAL.
 - c. AC/DC/GND : Waveform is operated toggling AC/DC/GND.
 - d. 0.1V/0.5V : Changes to two states of 0.5, 0.1V and applies only for CH3, 4 (only for 5100RA).
 - e. AC/DC : Changes waveform to AC/DC and applies only for CH3, 4(only for 5100RA).
 - f. CH2 INV : Changes the polarity of CH2 waveform.
 - g. CH3/CH4 : Selects CH3, 4 on QUAD (only for 5100RA).

14. HORIZONTAL BLOCK

- a. POSITION : Moves the X-axis position of sweep.
- b. TIME/DIV : Changes the time of sweep from 50ns to 5s with 1 - 2-5 step.
- c. X 10 MAG : Amplifies the X side of sweep 10 times.
- d. A/B : Selects A time, B time.

15. MODE KEY & SELECT KEY

- a. VERTICAL MODE : CH1, CH2, CH3, DUAL, ADD, QUAD.
(only for 5100RA)
- b. HORIZONTAL DISPLAY : A, B, ALT, X-Y.
- c. TRIGGER MODE : AUTO, NORM, TV-V, TV-H, SNGL.
- d. TRIGGER SOURCE : CH1, CH2, VERT, CH3, CH4, LINE.(only for 5100RA)
- e. TRIGGER COUPLING : AC, DC, HF-R, LF-R.
- f. SELECT : Marks the selection of each position with when mode keys are displayed.

16. MISCELLANEOUS FEATURES

- a. TEXT ON/OFF : Toggles the character on CRT as Mode Menu sign, Mode Menu clear sign and the whole screen clear by key input.
- b. AUTO SET : This key input lets the swept waveform of any position marked as suitable size and position.
- c. CURSOR : Moves cursor when it is displayed.
 - (1) V/ T : Toggles three cursors of Y-axis, X-axis and off.
 - (2) SELECT : This is cursor selection key which moves cursor with sign when cursor is displayed.
- d. TRIG LEVEL : This key adjusts waveform to be stable when it is swept. To select the trigger signal amplitude at which triggering occurs. When rotated clockwise, the trigger point moves toward the positive peak of the trigger signal.
When this control is rotated counterclockwise, the trigger point moves toward the negative peak of the trigger signal.

- e. HOLD OFF : This key is adjusted for the stable synchronism of waveform. This is used at the position 0% usually. Allows triggering on certain complex signals by changing the holdoff time of the main A sweep. The avoids triggering on intermediate trigger points within the repetition cycle of the desired display. The holdoff time increases with clockwise rotation.
- f. TRACE SEPARATION : Changes Y-axis position of B sweep on ALT selection of Hori display.
- g. DLY? POSITION : Changes X-axis position of B sweep on ALT selection of Hori display.
- h. SLOPE : Determines the starting point of the selection of rising edge and dropping edge of waveform.
- i. B TRIG? : On ALT selection of Hori Display, this is selected for synchronizing of B time.
- j. SGL READY : When Trigger Mode is on SNGL, this is selected for display of waveform each one time.
- k. ALT/CHOP : This can be selected when two or more waveform is displayed.
- l. BW LIMIT : This terminal diminishes 20MHz or more noise for diminishing high frequency noise.

2-2. REAR PANEL FUNCTION

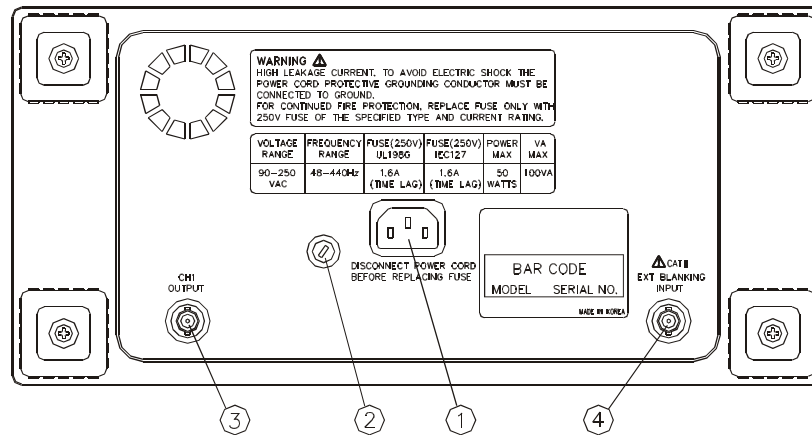

REAR

1. AC INLET : Connection and removal can be easy with the using of AC power cord.
2. FUSE
3. CH1 OUTPUT : Amplifies some part of signal which was input to CH1, and provides it for frequency counter or the other equipments.
4. EXT BLANKING INPUT: This terminal input signals for the brightness modulation of CRT. Brightness decreases with + signal input and it increases with- signal input.

2-3. INSTALLATION AND BASIC OPERATION

2-3-1. Character Display

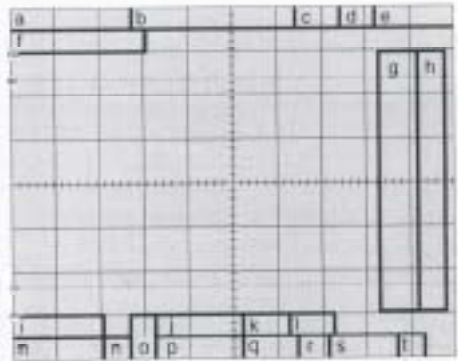

1. Description of each position

- a. When cursor is displayed, $\Delta TA(TB)$, $\Delta V1$ ($V2$, $V3$) are marked here.
- b. When cursor is displayed, $\Delta 1/TA$, and Auto Setup frequency are marked here.
- c. 'MG' is marked here on X 10 MAG.
- d. '>' is marked here on UNCAL of A Time DIV (pressed state).
- e. A Time DIV is marked here.
- f. HOLD OFF, TRIG LEVEL are marked here.
- g. VERT MODE, HORI DISPLAY, TRIGGER SOURCE, TRIGGER MODE, TRIGGER COUPLING MENU are marked here.
- h. Selection sign of select key is marked here.
- i. Contents of CH1 is marked here when VERT MODE is QUAD.
- J. Contents of CH2 is marked here when VERT MODE is QUAD.
- k. 'BW' is marked here on operation of BW LIMIT KEY.
- l. 'CHOP' is marked here on operation of ALT/CHOP KEY.
- m. Contents of CH1 is marked here when VERT MODE is CH1, DUAL, ADD.
Contents of CH3 is marked here when VERT MODE is CH3, QUAD.
- n. '+' sign is marked here on VERT MODE is ADD.
- o. ' ' sign is marked here with the operation of CH2 INVERT when VERT MODE is CH2, DUAL, ADD, QUAD.
- p. Contents of CH2 is marked here when VERT MODE is CH2, DUAL, ADD.
- q. 'B-T' is marked here on B TRIG?D KEY operation after ALT selecting of HORI Display.
- r. '>' is marked here on UNCAL when HORI display is B or ALT.
- s. B Time DIV of HORI display is marked here.
- t. '┌', '└' sign is toggled here on SLOPE KEY operation.

2-3-2. Initial Display

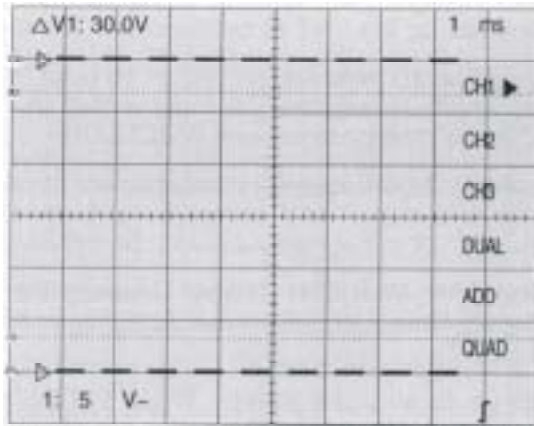

1. Setting at the power on

- a. VERT MODE : CH1
- b. HORI DISPLAY : A
- c. TRIGGER MODE : AUTO
- d. TRIGGER SOURCE : CH1
- e. TRIGGER COUPLING : AC
- f. TIME / DIV : 1ms
- g. VOLTS / DIV : 5V
- h. CURSOR : $\Delta V1$
- i. AC/DC/ GND : AC
- j. HOLD OFF : 0%
- k. SOUND : ON
- l. TEXT ON / OFF : ON

2-3-3. Probe Adjustment

When applying the external signal to measure using oscilloscope, use probe. The applied waveform is displayed on the CRT of oscilloscope. The product has two points :

$\times 1$ (direct connection) and $\times 10$ (attenuation). At $\times 10$ point, the input impedance of oscilloscope increases, which attenuates the input signal by 1/10. Therefore, it is necessary to multiply 10 to the measurement unit (VOLTS/DIV)

The damping probe is used for high frequency measurement because of the reduction of input capacity which distorts signal and reduces the load. Using any incorrectly calibrated probe may cause error in the measurement. So adjust the probe as follows :

1. Connect probe to CH1 X IN, With CH1 Trigger Coupling set to DC, connect tip to PROBE ADJUST. In this case, set the probe damping position to $\times 10$ and set VOLTS/DIV to 10mV.
2. Adjust TRIGGER LEVEL to stabilize screen. When the top or a part of spherical wave is slanted or has any tooth, adjust the probe adjustment trimmer as shown in Fig. PROBE COMPENSATION using small screw driver.

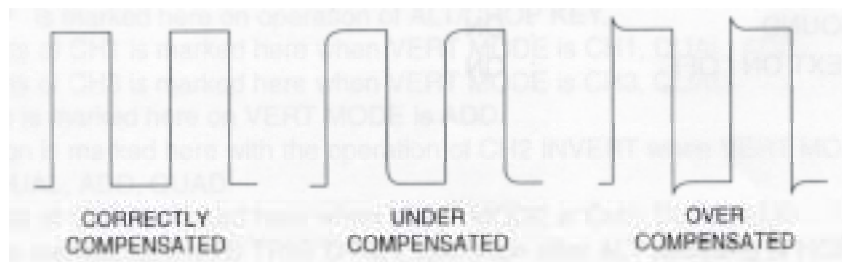
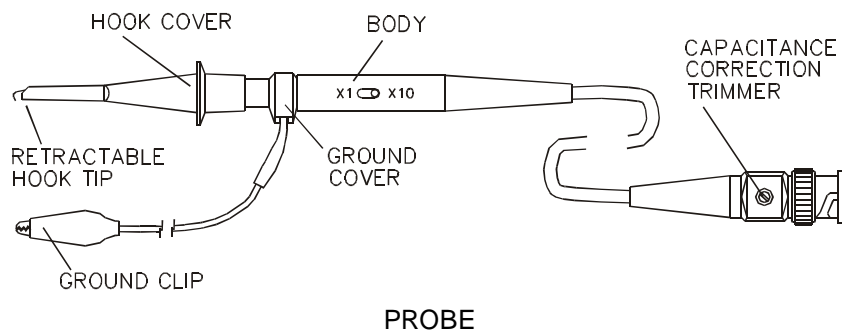

PROBE COMPENSATION

2-3-4. Vertical Mode

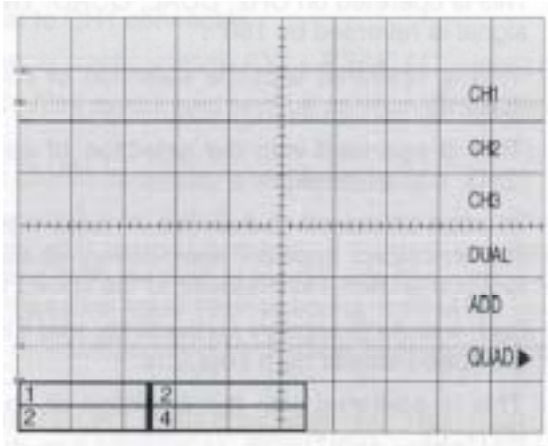

1. Menu Selection

- a. CH1 : When the first of select key is pressed, sign is displayed beside CH1 of screen and the content is displayed at the position of 3. only the signal which input to CH1 is displayed on CRT.
- b. CH2 : When the 2th of select key is pressed, sign is displayed beside CH2 of screen and the content is displayed at the position of 4. only the signal which input to CH2 is displayed on CRT.
- c. CH3 : When the 3th of select key is pressed, sign is displayed beside CH3 of screen and the content is displayed at the position of 3. only the signal which input to CH3 is displayed on CRT (only for 5100RA)
- d. DUAL : When the 4th of select key is pressed, sign is displayed beside DUAL of screen and the content is displayed at the position of 3. only the signal which input to CH1 and CH2 is displayed on CRT.
- e. ADD : When the 5th of select key is pressed, sign is displayed beside ADD of screen and the same contents of d. ??sign is displayed between 3, 4.

f. QUAD : When the 6th of select key is pressed, sign is displayed beside QUAD of screen and the content is displayed at the position of 1, 2, 3, 4. All signal which are input to CH1, 2, 3, 4 are displayed on CRT (only for 5100RA).

2. Switch

- a. CH2 INV : This is operated on CH2, DUAL, QUAD. The phase of CH2 input signal is reversed by 180°.
- b. VOLTS/DIV: This is operated with the selection of corresponding channel (CH1, 2).
- c. .1V/.5V : This is operated with the selection of corresponding channel (CH3, 4 of 5100RA).
- d. ALT/CHOP : This can be selected when two or more waveform is displayed.
- (1)ALT : The waveform appears alternatively at each sweep end.
This function is useful to measure at the speed faster than $50\mu\text{s}/\text{DIV}$.
- (2)CHOP : Each waveform appears concurrently, and it is useful to measure at the speed slower than $50\mu\text{s}/\text{DIV}$.
- e. AC/DC/GND: This is operated with the selection of corresponding channel (CH1, 2).
- (1)AC : AC position inserts a capacitor between the input connector and amplifier to block any DC components in the input signal.
- (2)DC : DC position connects the amplifier directly to its input connector, thus passing all signal components on to the amplifier.
- (3)GND : GND position connects the amplifier to ground instead of the input connector, so a ground reference can be established.
- f. AC/DC : This is operated with the selection of corresponding channel (CH3, 4 of 5100RA).
- g. X10 MAG : This amplifies TIME/DIV state 10 times. In this case, sweep time becomes one tenth the TIME/DIV value. Pulling the $\times 10$ MAG switch when the zone to be magnified is aligned with the center scale of vertical axis by adjusting the horizontal axis, the magnified waveform appears in symmetry. In this case, sweep time becomes one tenth the TIME/DIV value.

2-3-5. Channel Connections

1. Connect the signal to CH1 connector.

<Note> Do not apply power voltage (DC + PEAK AC) higher than 400V.

2. Adjust CH1 VOLTS/DIV switch and vertical position terminal to place the signal in the measurable area.

3. Adjust TRIGGER LEVEL to display a stable waveform.

4. Set HORI Display on A and adjust it to be on the area in which waveform can be measured by horizontal position terminal. If the measurement is difficult for many cycles of measuring high frequency signal with the setting the A position of HORI Display on 50ns, measure again after selecting $\times 10$ MAG.

5. When measuring any damped or distorted low frequency signal, set the TRIGGER COUPLING to DC.

6. For input of signal to CH3 input connector, set TRIGGER COUPLING to AC and adjust .1/.5 switch and VERTICAL POSITION switch to be on the area in which signal can be measured.

2-3-6. Horizontal Display

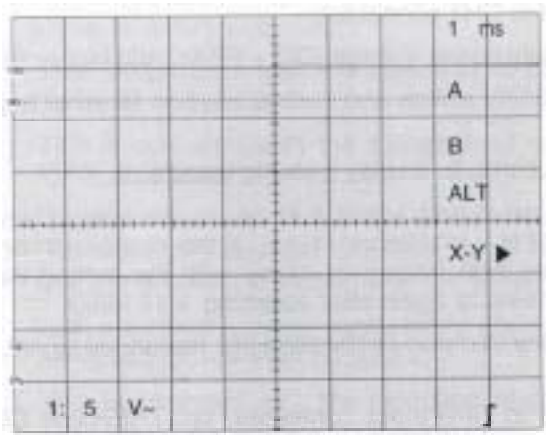

1. Menu Selection

- a. A : Sweep Time of main time axis is displayed. (position 'e' fig. 2-3-1)
- b. B : Sweep Time of delayed time axis is displayed. (position 's' fig. 2-3-1)
Modelated brightness part is displayed on the whole screen with amplified state.
- c. ALT : This displays sweep time of A Time and B Time at the same time and B Time is the emphasized part of a time. The position of emphasized part is determined with the adjustment of DLY'D position A(B) sweep is displayed by A(B) TIME/DIV.
- d. X-Y : CH1 is X-axis and CH2 is Y-axis. Internal time axis is not used on measuring X-Y and both horizontal and vertical deflection are operated with external signal. On X-Y mode, the connector which is related with Trigger switch is not operated. The height of brightness is adjusted with CH2 VOLTS/DIV switch and the width of it is adjusted with CH1 VOLTS/DIV switch.

2. Switch

- a. A/B : This is operated on ALT selection. When HORI Display is selected to B, LED becomes ON and toggled.
- b. B-TRIG D : The delay sweep is triggered by the first trigger pulse.
- c. DLY D POSITION : To determine the exact starting point within the A sweep delay range at which the B sweep will begin sweeping.
- d. TRACE SEPARATION : It is used to vertically move the sweep of B when HORIZ DISPLAY is ALT.

2-3-7. Trigger Mode

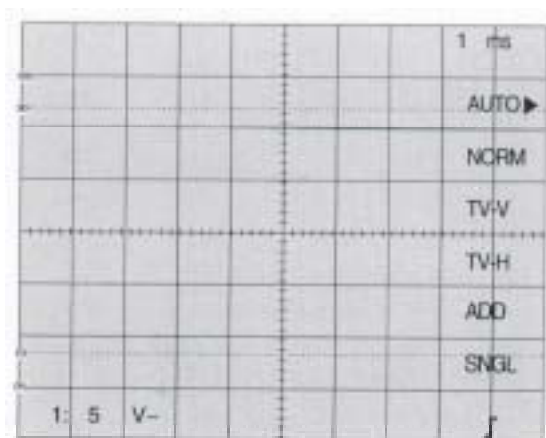

1. Menu Selection

- a. **AUTO** : AUTO position selects free-running sweep where a baseline is displayed in the absence of a signal. This condition automatically reverts to triggered sweep when a trigger signal of 25Hz or higher is received and other trigger controls are properly set.
- b. **NORM** : NORM position produces sweep only when a trigger signal is received and other controls are properly set. No trace is visible if any trigger requirement is missing. This mode must be used when the signal frequency is 25Hz or lower.
- c. **TV-V** : TV-V position is used for observing a composite video signal at the frame rate.
- d. **TV-H** : TV-H position is used for observing a composite video signal at the line rate.
- e. **SNGL** : This is used for measuring single signal.

2. Switch

- a. **SINGLE READY**: On selection of single, sweep is appeared only by press of terminal.

2-3-8. Trigger Source

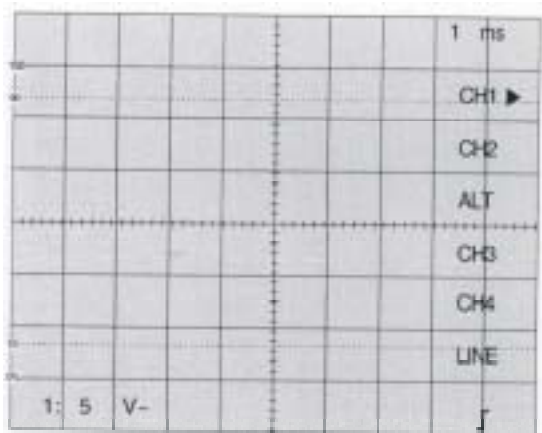

1. Menu Selection

- a. CH1 : When the signal is on CH1, the stable waveform can be observed by the selection of CH1 with TRIGGER SOURCE.
- b. CH2 : When the signal is on CH2, the stable waveform can be observed by the selection of CH2 with TRIGGER SOURCE.
- c. VERT : When the signal is on CH1, 2 the stable waveform can be observed by the selection of VERT with TRIGGER SOURCE.
- d. CH3 : When the signal is on CH3, the stable waveform can be observed by the selection of CH3 with TRIGGER SOURCE
(only for 5100RA)
- e. CH4 : When the signal is on CH4, the stable waveform can be observed by the selection of CH4 with TRIGGER SOURCE.
(EXT when 5100RB)
- f. LINE : This is used for measuring synchronized signal on the frequency of AC power. The component of measured signal can be observed stably.

2-3-9. Trigger Coupling

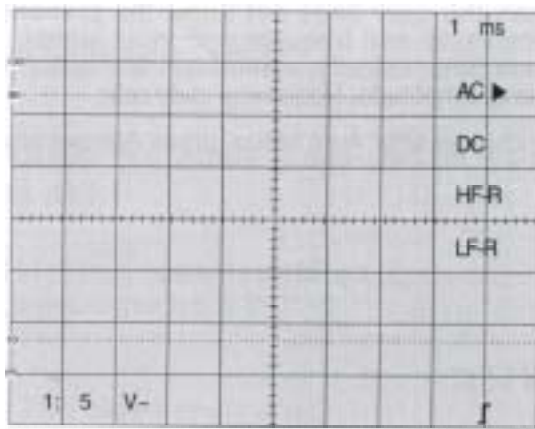

1. Menu Selection

- a. AC : Signal passes through capacitor and connects with the input terminal of trigger generator circuit. At this time, the DC signal is screened off, and AC signal with frequency below 30Hz is attenuated.
- b. DC : Signal is directly connected with the input terminal of trigger generator circuit.
- c. HF-R : Signal passes through low pass filter and connects with the input terminal. At this time DC signal is screened off and AC signal with frequency below 30Hz or above 4kHz is attenuated. This stabilizes the measurement of low frequency signal by eliminating the high frequency component in the low frequency signal.
- d. LF-R : Signal passes through high pass filter, and connects with the input terminal. The signal with frequency below 4kHz is attenuated. This stabilizes the measurement of high frequency signal by eliminating the low frequency component in the high frequency signal.

2-3-10. Auto setup

Press Autoset key when the user does not know the present setting condition of oscilloscope, or the amplitude and frequency of input signal. This sets amplitude, frequency, and waveform automatically, sometimes the option state may not be set because of the difference of amplitude, frequency, duty ratio.

If input signal frequency change after Auto setup, press Autoset key again.

1. Auto Setup

a. VERTICAL PARTS

- (1) VOLTS/DIV : This is changed from 2mV to 5V so that it can be 2~7DIV in correspondence of input signal.
- (2) VARIABLE : CAL
- (3) CHANNEL DISPLAY :
 - (a) CH1 : This is marked when CH1, CH3, ADD, QUAD are selected on VERT MODE.
 - (b) CH2 : This is marked when CH2 is selected on VERT MODE.
 - (c) DUAL : This is marked when DUAL is selected on VERT MODE.
- (4) POSITION : CENTER
- (5) AC/DC/GND : AC
- (6) ALT/CHOP : ALT
- (7) CH2 INV : OFF
- (8) BW LIMIT : OFF

b. TRIGGER PART

- (1) TRIGGER MODE : AUTO
- (2) TRIGGER SOURCE : This is determined by VERT MODE.
- (3) TRIGGER COUPLING : AC
- (4) SLOPE : RISING
- (5) TRIGGER LEVEL : This is changed by the shape of waveform.

c. HORIZONTAL PART

- (1) HORIZ DISPLAY : A
- (2) TIME/DIV : Set this so that the cycle can be displayed from 2 to 5.
- (3) VARIABLE : CAL
- (4) POSITION : CENTER
- (5) X 10MAG : This becomes ON when 10MHz or more waveform is input.

2-3-11. Cursor

1. Sound ON / OFF.

When press Cursor key, Sound is ON/OFF.

2. $\Delta V1(\Delta V2, \Delta V3)$

On DUAL, ADD, QUAD, ΔV cursor is operated on the basis of CH1, so the expression becomes $\Delta V1$.

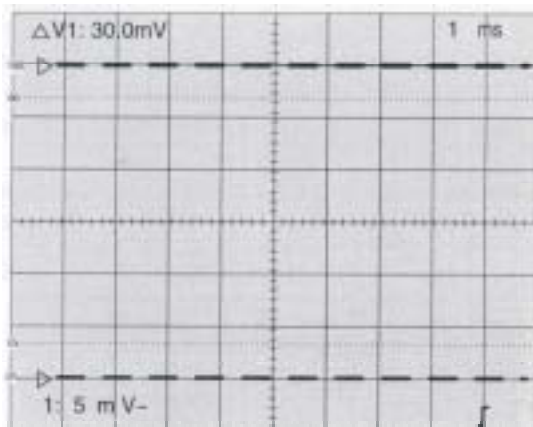

3. $\Delta TA(\Delta TB), 1/\Delta TA(1/\Delta TB)$ CURSOR

When HORI Display is A(B), $\Delta TA(TB)$ is displayed and when HORI Display is ALT, the display of the previous level does not change, $\Delta TA(TB)$ is changed with conversion of A/B terminal.

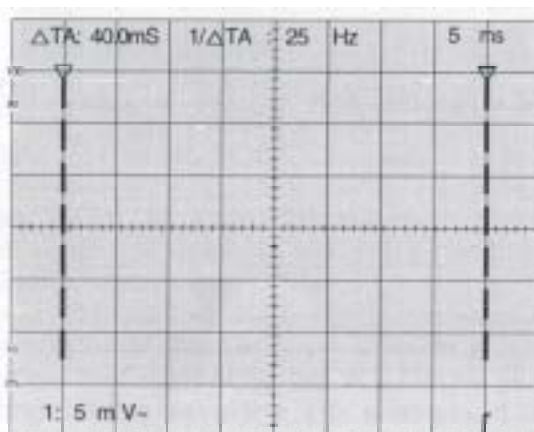

2-3-12. X-Y Cursor

1. $\Delta V1$ ($\Delta V2$) CURSOR

On DUAL, ADD, QUAD, ΔV cursor is operated on the basis of CH1, so the expression becomes $\Delta V1$, On X-Y, CH3 does not operate alone.

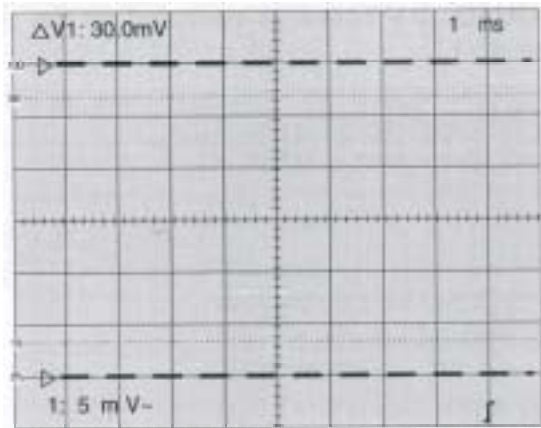

2. $\Delta V1$ CURSOR

On X-Y, ΔTA is expressed as $\Delta V1$ and change to VOLTS/DIV of CH1. Though the channel of VERT MODE is changed, the value is operated on the basis of CH1.

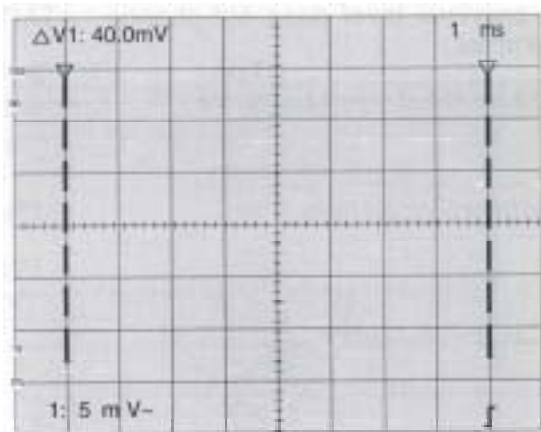

2-4. MEASUREMENT APPLICATIONS

This section contains instructions for using your Oscilloscope for specific measurement procedures. However, this is but a small sampling of the many applications possible for this oscilloscope. These particular applications were selected to demonstrate certain controls and features not fully covered in BASIC OPERATING PROCEDURES, to clarify certain operations by example, or for their importance and universality.

2-4-1. Voltage measurements

Oscilloscope voltage measurement generally falls into one of two types : peak-to-peak or instantaneous peak-to-peak (p-p) measurement simply notes the total amplitude between extremes without regard to polarity reference. Instantaneous voltage measurement indicates the exact voltage from each every point on the waveform to a ground reference.

All voltage measurement is possible from simple waveform using oscilloscope to complicate waveform.

1. Peak-to-peak voltage.

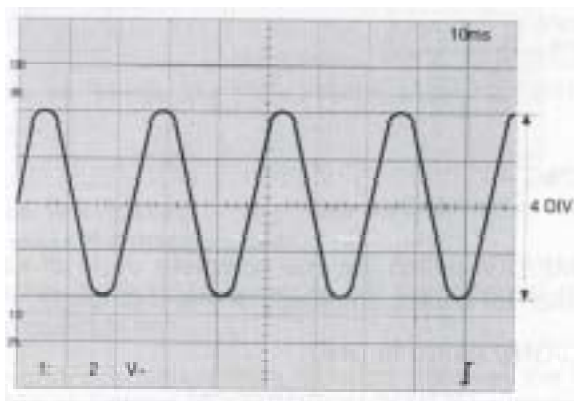

- a. Adjust the TIME/DIV switch for 2~3 cycles of waveform, and set the VOLTS/DIV switch and for the largest-possible totally-on-screen display.
- b. Use the appropriate VERTICAL POSITION control or to position the negative signal peaks on the nearest horizontal graticule line below the signal peaks.
- c. Use the appropriate VERTICAL POSITION control to position one of the position peaks on the central vertical graticule line. (This line has additional calibration marks equal to 0.2 major division each).

- d. Count the number of division from the graticule line touching the negative signal peaks to the intersection of the positive signal peak with the central vertical graticule line. Multiply this number by the VOLTS/DIV switch setting to get the peak-to-peak voltage of the waveform. For example, if the VOLTS/DIV switch was set to 2V. ($4.0\text{DIV} \times 2\text{V} = 8.0\text{V}$)
 - e. If $\times 10$ attenuator probes are used, multiply the voltage by 10.
 - f. If measuring a sine wave below 100Hz, or a rectangular wave 1kHz, flip the AC/DC/GND switch to DC.
- <Note>With the waveform to which high voltage is applied, it is impossible to measure as described above. In this case, set AC/DC/GND switch to AC prior to measurement. (When it is necessary to measure AC component)

2. Instantaneous Voltage Measurements

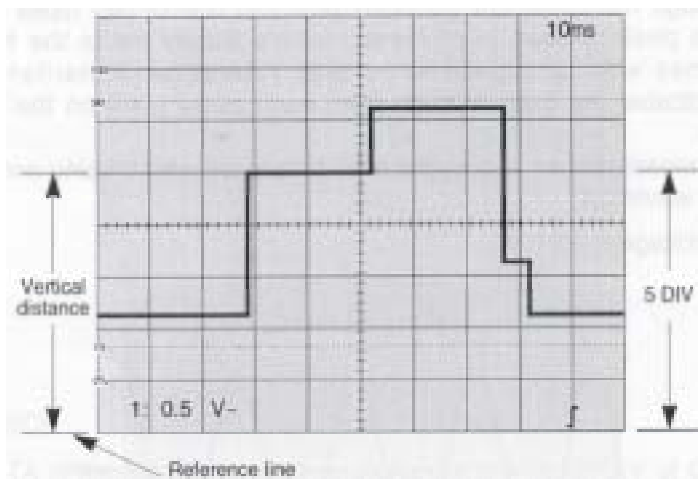

- a. Adjust the TIME/DIV switch for one complete cycle of waveform, and set the VOLTS/DIV switch for a trace amplitude of 4 to 6 divisions.
 - b. Flip the AC/DC/GND switch to GND.
 - c. Use the appropriate VERTICAL POSITION control to set the baseline on the central horizontal graticule line.
- However, if you know the signal voltage is wholly positive, use the bottommost graticule line. If you know the signal voltage is wholly negative, use the uppermost graticule line.
- <Note> The VERTICAL POSITION controls must not be touched again until the measurement is completed.

- d. Flip the AC/DC/GND switch to DC. The polarity of all points above the ground-reference line is positive ; all points below the ground-reference line are negative.
<Caution> Make certain the waveform is not riding on a high-amplitude DC voltage before flipping the AC/DC/GND switch.
- e. Use the HORIZONTAL POSITION control to position any point of interest on the central vertical graticule line. This line has additional calibration marks equal to 0.2 major division each. The voltage relative to ground at any point selected is equal to the number of division from that point to the ground-reference line multiplied by the VOLTS/DIV setting. In the example used the voltage for a 0.5V/DIV scale is 2.5V ($5.0\text{DIV} \times 0.5\text{V} = 2.5\text{V}$)
- f. If $\times 10$ attenuator probes are used, multiply the voltage by 10.

2-4-2. Time interval measurements

This is possible because the calibrated timebase results in each division of the CRT screen representing a known time interval.

1. Basic technique measurement

The basic technique for measuring time interval is described in the following steps. This same technique applies to the more specific procedures and variations that follow.

- a. Set up oscilloscope as described in 2-3-2 Initial Display.
- b. Set the A TIME/DIV switch so that the interval you watch to measure is totally on screen and as big as possible. Make certain the A VARIABLE control is click-stopped fully clockwise. If not, any time interval measurements made under this condition will be inaccurate.
- c. Use the VERTICAL POSITION control to position the trace so the central horizontal graticule line passes through the points on the waveform between which you want to make the measurement.
- d. Use the HORIZONTAL POSITION control to set the left-most measurement point on a nearly vertical graticule line.

- e. Count the number of horizontal graticule divisions between the Step 'd' graticule line and the second measurement point. Measure to a tenth a major division. Note that each minor division of the central horizontal graticule line is 0.2 major division.
- f. To determine the time interval between the two measurement points, multiply the number of horizontal divisions counted in Step e by the setting of the TIME/DIV switch. If the $\times 10$ MAG switch is pushed, be certain to divided the TIME/DIV switch setting by 10.

2. Period, pulse width, and duty cycle measurement

The basic operation described in the preceding paragraph can be used to determine pulse parameters such as period, pulse width, duty cycle, etc. The Period of a pulse or any other waveform is the time required for one full cycle of the signal. In Fig. 10ms the distance between points A and C represent one cycle ; the time interval of this distance is 70 milli-seconds in this examples.

Pulse width is the distance between points A and B. It is conveniently 1.5 DIV, so the pulse width is 15ms. However, 1.5DIV is a rather small distance for accurate measurements, so it is advisable to use a faster sweep speed for this particular measurement. Increasing the sweep speed to 2ms/DIV as in Fig. 2ms. B gives a large display, allowing more accurate measurement. Pulse width is also called on time in some application. The distance between points B and C is then called off time. This can be measured in the same manner as pulse width.

When pulse width and period are known, duty cycle can be calculated. Duty cycle is the percentage of the period (or total of on and off times) represented by the pulse width (on time). In Fig. 10ms, the duty cycle is as follows :

$$\text{Duty cycle(\%)} = \frac{\text{Pulse Width}}{\text{Period}} \times 100 = \frac{A \ B}{A \ C} \times 100$$

$$\text{(ex)Duty cycle(\%)} = \frac{15\text{ms}}{70\text{ms}} \times 100 = 21.4\%$$

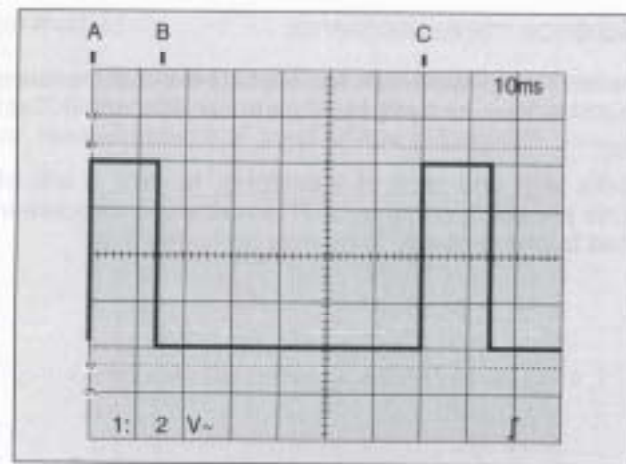

10ms INTERVAL

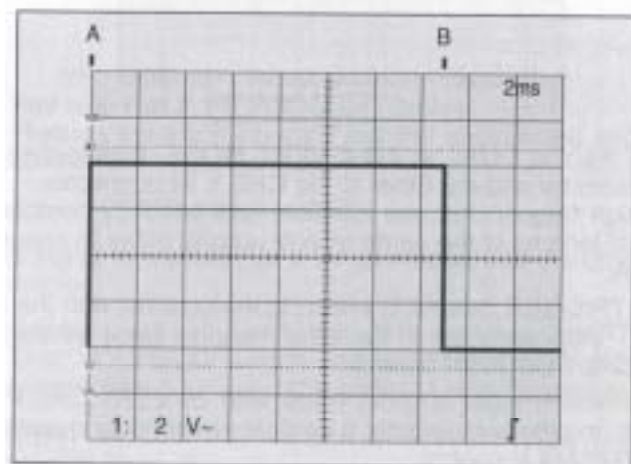

2ms INTERVAL

2-4-3. Frequency measurement

When a precise determination of frequency is needed, a frequency counter is obviously the first choice. A counter can be connected to the CH1 OUTPUT connector for convenience when both oscilloscope and frequency counter are used. However, and oscilloscope alone can be used to measure frequency when a frequency counter is not available, or modulation and/or noise makes a counter unusable.

1. Frequency under 50MHz is instantly displayed on CRT screen on pressing Auto Set Key
2. Take the reciprocal number of cursor space when ΔT is selected by pressing of cursor key, and display the frequency on CRT screen with the space of two cursors.

2-4-4. Phase difference measurements

Phase difference in phase angle between two signals can be measured using the dual-trace feature of the oscilloscope, or by operation the oscilloscope in the X-Y mode.

1. Dual-trace Method

This method works with any type of waveform. In fact, it will often work even if different waveforms are being compared. This method is effective in measuring large or small differences in phase at any frequency up to 100kHz

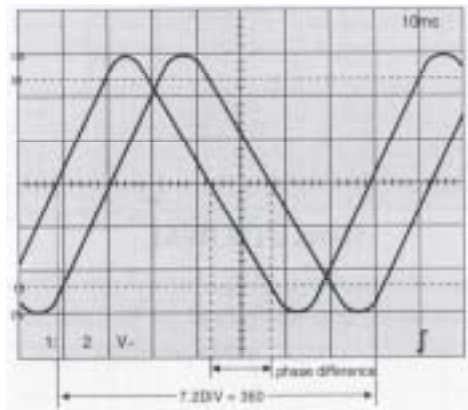

- a. Set SELECT KEY is DUAL at 2-4-4 VERT MODE. Connecting one signal to the CH1 X IN connector and the other to the CH2 Y IN connector.
<Note> At high frequencies use identical and correctly compensated probes, or equal lengths of the same type of coaxial cable to ensure equal delay times.
- b. Position the TRIGGER SOURCE switch to the channel with the cleanest and most stable trace. Temporarily move the other channel trace off the screen by means of its VERTICAL POSITION control.
- c. Center the stable (trigger source) trace with its VERTICAL POSITION control, and adjust its amplitude to exactly 6 Vertical divisions by means of its VOLTS/DIV switch and VARIABLE control.
- d. Use TRIGGER LEVEL control to ensure that the trace crossing the central horizontal graticule line at or near the beginning of the sweep.
- e. Use the A TIME/DIV switch, TIME VARIABLE, and the HORIZONTAL POSITION to display one cycle of trace over 7.2 divisions. When this is done, each major horizontal division represents 50° , and each minor division represents 10° .
- f. Follow the procedure as described in Step 'c' so that the off-screen waveform is placed on the horizontal scale.

- g. The horizontal distance between corresponding points on the waveform is the phase difference. For example, the phase difference is 1.2 major divisions, or 60° .
- h. If the phase difference is less than 50° (one major division) it is possible to conduct a finer measurement with $10 \times$ magnification, each major division is 5° and each minor division is 1° .

2. Lissajous pattern method

This method is used primarily with sine waves. Measurements are possible for the frequencies up to 100kHz, the bandwidth of the horizontal amplifier. However, for maximum accuracy, measurements of small phase differences should be limited to below 100kHz.

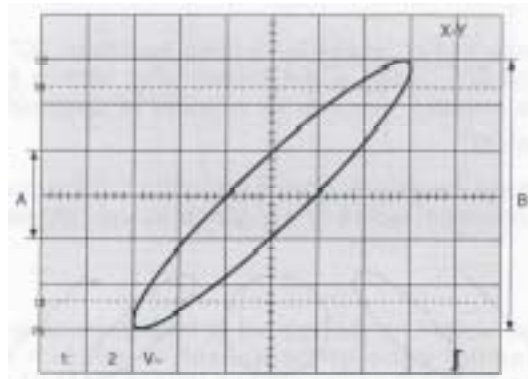

- a. Set Select Key is X-Y at 2-3-6 Horizontal Display.
<Caution> Reduce the trace intensity lest the undeflected spot damage the CRT phosphor.
- b. Make sure the $\times 10$ MAG switch is OFF.
- c. Connect one signal to the CH1 or X IN connector, and the other signal to the CH2 or Y IN connector.
- d. Center the trace vertically with the CH2 vertical POSITION control. And adjust the CH2 VOLTS/DIV switch and VARIABLE control for a trace height of exactly 6 divisions (the 100% and 0% graticule lines tangent to the trace).
- e. Adjust the CH1 VOLTS/DIV switch and VARIABLE for the horizontal 6 divisions shown in Step 'd'.

- f. Precisely center the trace horizontally with the Horizontal POSITION control.
- g. Count the number of divisions along the central vertical graticule line. You can now shift the trace vertically with CH2 POSITION control to a major division line for easier counting.
- h. The phase difference (angle) between the two signals is equal to the arcsine of dimension A, B (the Step 'g' number divided by 6). For example, in the Step 'g' value of the Fig., pattern is 2.0. Dividing this by 6 yields 0.3334, whose arcsine is 19.5°.

$$\text{The phase difference(angle)} = \sin^{-1} \frac{A}{B}$$

- i. The simple formula in Fig. works for angles less than 90° for angles over 90° (leftward tilt), and 90° to the angle found. Fig. shows the Lissajous patterns of various phase angles : use this as a guide in determining whether or not to add the additional 90°.

<Note>The sine-to-angle conversion can be accomplished by using trigonometrical tables or a trigonometrical calculator.

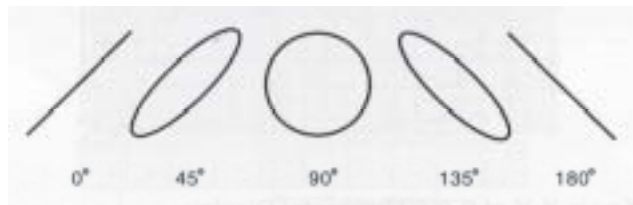

2-4-5. Transition time measurement

Risetime is the time required for the leading edge of a pulse to rise from 10% to 90% of the total pulse amplitude. Falltime is the time required for the trailing edge of a pulse to drop from 90% of total pulse amplitude to 10%. Risetime and falltime, which may be collectively called transition time, are measured essentially in the same manner.

To measure rise and fall time, proceed as follows :

- a. Connect the pulse to be measured to the CH1 X IN connector, and set the AC/DC/GND switch to AC.

- b. Adjust the A TIME/DIV switch to display about 2 cycles of the pulse. Make certain the A VARIABLE control is rotated fully clockwise and pushed in.
- c. Center the pulse vertically with the channel 1 Vertical Position control.
- d. Adjust the channel VOLTS/DIV switch to make the positive pulse peak exceed the 100% graticule line, and the negative pulse peak exceed the 0% line, rotate the VARIABLE control counterclockwise until the positive and negative pulse peaks rest exactly on the 100% and 0% graticule line.
- e. Use the Horizontal POSITION control to shift the trace so the leading edge passes through the intersection of the 10% and central vertical graticule lines.

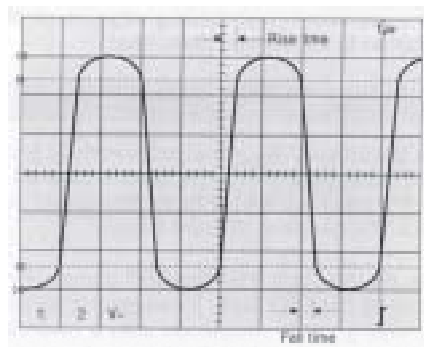

- f. If the risetime is slow as compared to the period, no further control manipulations are necessary. If the risetime is fast (leading edge almost vertical), pull the A VARIABLE/PULL $\times 10$ MAG control and reposition the trace as in Step 'e'.
- g. Count the number of horizontal divisions between the central vertical line (10% point) and the intersection of the trace with the 90% line.
- h. Multiply the number of divisions counted in Step 'g' by the setting of the TIME/DIV switch to find the measured risetime. If $\times 10$ magnification was used, divide the TIME/DIV setting by 10. For example, if the A timebase setting in Fig. was 1s/DIV (1000ns), the risetime would be 360 ns (1000ns \div 10=100ns, 100ms \times 3.6DIV =360ns).
- i. To Measure falltime, simply shift the trace horizontally until a trailing edge passes through the 10% and central vertical graticule lines, and repeat Steps 'g' and 'h'.
- j. When measuring the rise and fall time, note that 3.5ns (Rise time (t_r)) which is transition time is contained in oneself. Therefore the real transition time (t_c) is composed of measure transition time (t_m) and t_r . The above all is explained with following formula :

$$t_c = \sqrt{t_m^2 - (0.35ns)^2}$$

t_c = Real transition time

t_m = Measured transition time

3. USER MAINTENANCE GUIDE

Maintenance routines performable by the operator are listed in this section. More advanced routines (i.e., procedures involving repairs or adjustments within the instrument) should be referred to EZ service personnel.

3-1. CLEANING

If the outside of the case becomes dirty or stained, carefully wipe out the soiled surface with a cloth moistened with detergent, then wipe out the cleaned surface with a dry cloth. In case of severe stain, try cleaning with a cloth moistened with alcohol. Do not use powerful hydrocarbons such as benzene or paint thinner.

Dust and/or smudges can be removed from the CRT screen, first remove the front case and filter. Clean the filter (and the CRT face, if necessary) by wiping out carefully with a soft cloth or commercial wiping tissue moistened with a mild cleaning agent. Take care not to scratch them. Do not use abrasive cleaner or strong solvents. Let the cleaned parts dried thoroughly before reinstalling the filter and front case. If it is installed wet, water rings may form and blur the waveforms. Be particularly careful not to get fingerprints on the filter or CRT face.

3-2. CALIBRATION INTERVAL

To maintain the accuracy specifications of the calibration checks and procedures should be performed after every 1000 hours of service. However, if the instrument is used infrequently, the calibration checks should be performed every six months.

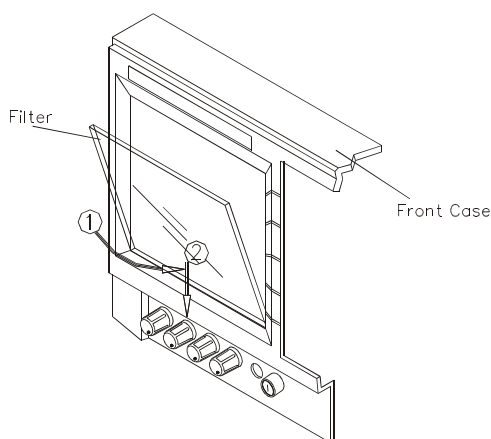

4. DIAGRAMS

4-1. EXTERNAL VIEWS (OS-5100RA)

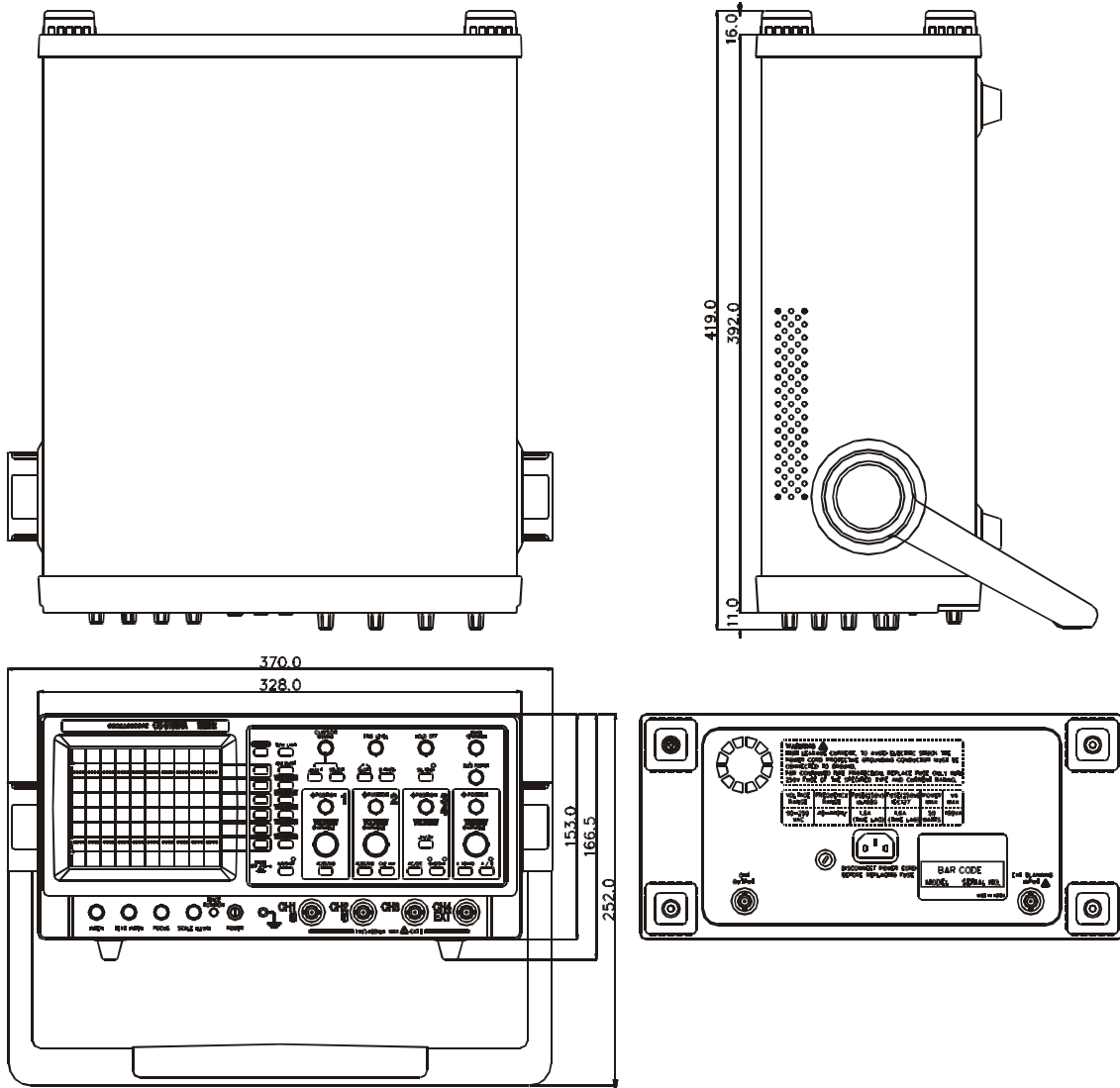

4-2. BLOCK DIAGRAM (OS-5100RA)

